

Brake & tow system



Trailers for automotive plants

## BESPOKE WHEELING, BRAKE SYSTEMS AND TOW BARS



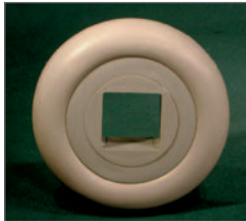

We are able to design and supply wheeling and castor systems for specific customer requirement. We have over 30 years experience in providing solutions for the automotive, aeronautical, chemical and pharmaceutical industries.

- Heavy duty wheeling systems for the most demanding applications.
- Bespoke tow systems.
- Braking parts and speed reduction systems.
- Noise reduction systems.
- Shock absorption solutions.



## TROLLEY BUFFERS

This series offers buffers which are fitted to the vertical leg (whether round or square) of a trolley above the castor. Should the trolley come too close to a wall, the buffer comes in contact with the wall and turns as the trolley is pushed along the wall offering protection to both wall and trolley. This type of the buffer is made from hard wearing foamed plastic which is a non marking material.

Foamed Plastic Buffer							
		round or square				REF	PRICE
114	30	R	0.05	25	1"	R1	£4.80
114	30	S	0.05	25	1"	S1	£6.99
114	30	S	0.05	25	32	S32	£6.80
114	30	R	0.05	25	32	R32	£6.03

## EXPANDER CASTOR FITTINGS

- Black nylon 6 and is fitted to an M10 hexagonal headed set screw.
- For attaching a bolt hole type castor to a tube or square hollow section.
- The maximum recommended load for these expander fittings is 100Kg.
- It is important not to over tighten as this can damage the expander causing the castor to become loose.
- The maximum recommended torque for nylon expanders is 15 decanewtons however this can be effected by the gauge of the steel section into which the expander is fitted.
- We advise an expander should not be used where there are large temperature variations.

### Expanders for Round Tube

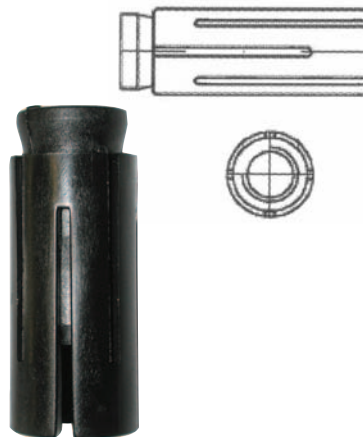

REF	Internal diameter	PRICE
EXPC19R	19-21	£2.50
EXPC22R	22-23	£2.58
EXPC24R	24-26	£2.64
EXPC27R	27-29	£2.83
EXPC30R	30-32	£2.98

### Expanders for Square Tube

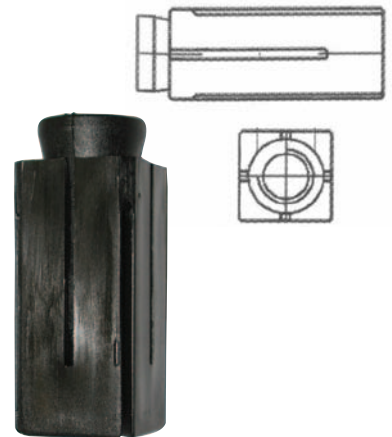

REF	Internal diameter	PRICE
EXPC20S	20-21.5	£2.58
EXPC22S	22-24	£2.64
EXPC25S	25-27	£2.78
EXPC30S	30-32	£2.98
EXPC36S	36-38	£3.10