



DRUM CRADLE STANDS

These stands are suitable for the storage and movement of heavy duty drums. Heavy duty steel welded construction for all industrial settings.

- Capacity: 400kg.
- Epoxy powder coated black finish.
- Choice of 6 styles all able to have optional handle lever fitted for easy dispensing of drum contents and moving of cradle.

new

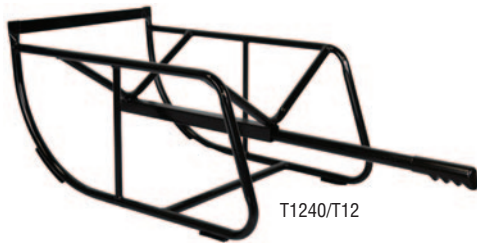

T1240/T12



T1244

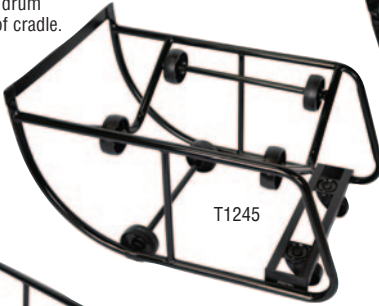

T1245



T1243



T1241



T1242

REF	Description	Wheels	Roller dia mm	Overall size L x W x H mm	Height of tap hole mm	PRICE
T1240	Static drum cradle stand	-	-	889 x 559 x 381	330	£112.58
T1241	Mobile drum cradle stand	75mm wheels	-	889 x 559 x 430	368	£183.08
T1242	Mobile drum cradle stand	75mm wheels & 50mm swivel castors	-	889 x 559 x 430	368	£203.93
T1243	Static drum cradle stand	-	75	889 x 559 x 381	368	£195.15
T1244	Mobile drum cradle stand	75mm wheels	75	889 x 559 x 430	405	£265.71
T1245	Mobile drum cradle stand	75mm wheels & 50mm swivel castors	75	889 x 559 x 430	406	£286.50
T12HANDLE	Drum handle lever which can be fitted to any drum cradle stand			L 1066	-	£0.00



MOBILE DRUM STAND WITH TILT LEVER

- Capacity 250kg for 210 litre steel drums.
- Welded steel construction.
- 2 fixed outrigger wheels 150 x 40mm.
- 2 swivel castors nylon wheels 80 x 35mm.
- Tilt lever and drum rotation rollers.
- Finish: red epoxy.
- O/A L x W x H: 880 x 725 x 580mm.



REF	PRICE
DS19	£379.68

DOUBLE HANDLE MOBILE DRUM CRADLE



Capacity 270kg for 210 litre steel drums and certain plastic types.



- Horizontal position for moving with tilt action double handles.
- O/S L x W x H: 1200 x 400 x 451mm.
- Nylon wheels 125mm and 100mm swivel castors.

REF	PRICE
DC270Y	£278.14