

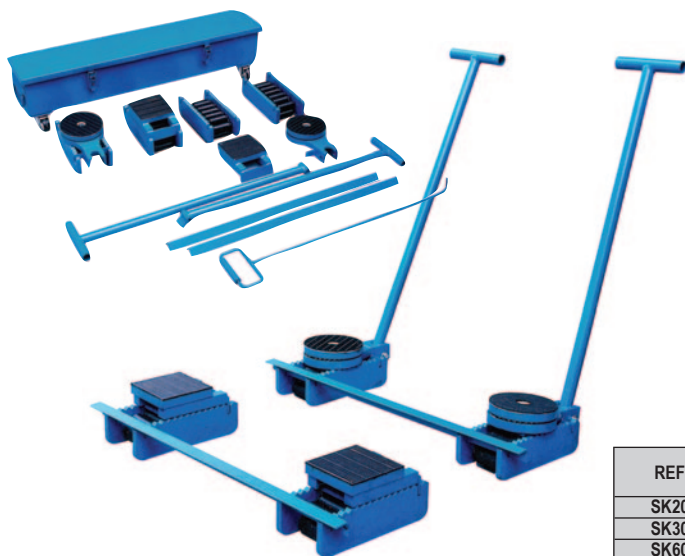

Our expert says

Avoid damage to floors Use skates to even the load

HEAVY HANDLING AIDS



CATERPILLAR SKATE KIT

Quick way of moving heavy plant and equipment over short, variable distances.

- Steering handle enables movement of loads in very tight spots.
- Moving speed not exceeding 5m/min.
- Minimum turning circle 3m.
- Heavy duty carry box.

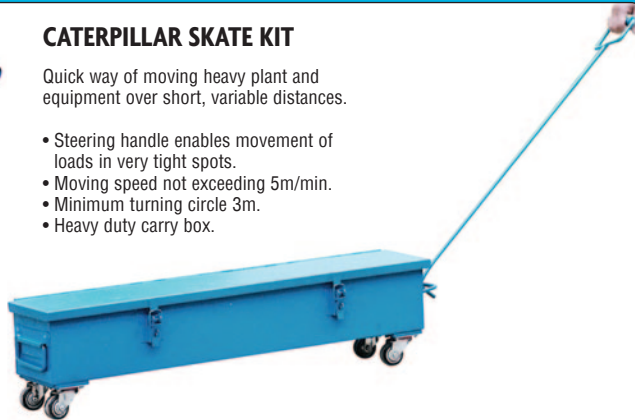

REF	Capacity per set kg	Total height mm	Dia rollers mm	Rollers	Weight kg	PRICE
SK20	20000	108	18	steel	50	£520.63
SK30	30000	117	24	steel	59	£590.45
SK60	60000	140	30	steel	92	£796.25

REAR ADJUSTING SKATES WITH CONNECTING RODS

Supplied as a pair of skates with connecting rods to be able to make the skates adjustable (500 - 1400mm for CM60 and 720 - 1500mm for models CM120/CM240).

- Maintenance-free.
- Rubber surface to protect load.

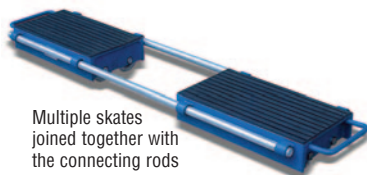

Multiple skates joined together with the connecting rods



REF	Capacity per set kg	Rollers	Size mm	Weight kg	PRICE
CM60	6000	8 nylon	300 x 250 x 115	30	£294.00
CM120	12000	12 nylon	360 x 220 x 115	38	£404.25
CM240	24000	16 steel	360 x 220 x 115	65	£580.65

FRONT STEERABLE SKATES WITH HANDLE

Choice of 3 skates that come complete with a front steerable handle.

- Avoids point load damage to floors.
- Protective rubber surface.
- Easy to move and position under machinery and plant.



REF	Capacity per set kg	Rollers	Size mm	Weight kg	PRICE
ST30	3000	4 nylon	310 x 255 x 105	15	£171.50
ST60	6000	8 nylon	630 x 400 x 115	50	£416.50
ST120	12000	8 steel	630 x 400 x 115	66	£490.00

FIXED SKATES

Swim design to facilitate easy positioning under awkward loads.

- Top rubber surface to protect loads.
- Carrying handles.
- Capacities from 1000 - 6000kg.



REF	Capacity kg	Rollers	Size mm	Weight kg	PRICE
SF10/A	1000	4 nylon	320 x 220 x 120	7	£78.40
SF20/A	2000	8 nylon	330 x 220 x 120	8	£122.50
SF25/A	2500	2 nylon	210 x 100 x 105	4	£78.40
SF30/A	3000	4 nylon	330 x 300 x 120	9.5	£116.38
SF60/A	6000	6 nylon	260 x 230 x 105	12	£164.15

ECONOMY SKATE WITH CASTORS

Easy to use lightweight shifting skate. Suitable for machinery, plant and office equipment.

- Carrying handle.
- Choice of two wheeling types.
- Rubber top platform to protect load.



REF	Capacity kg	Wheels	Size mm	Weight kg	PRICE
SC102/A	1000	2 fixed & 2 swivel	430 x 340 x 120	13	£161.70
SC104/A	1000	4 swivel	430 x 340 x 120	14	£196.00

Prices include delivery on orders over £150